

## Special Drive Unit for Extractor Hood

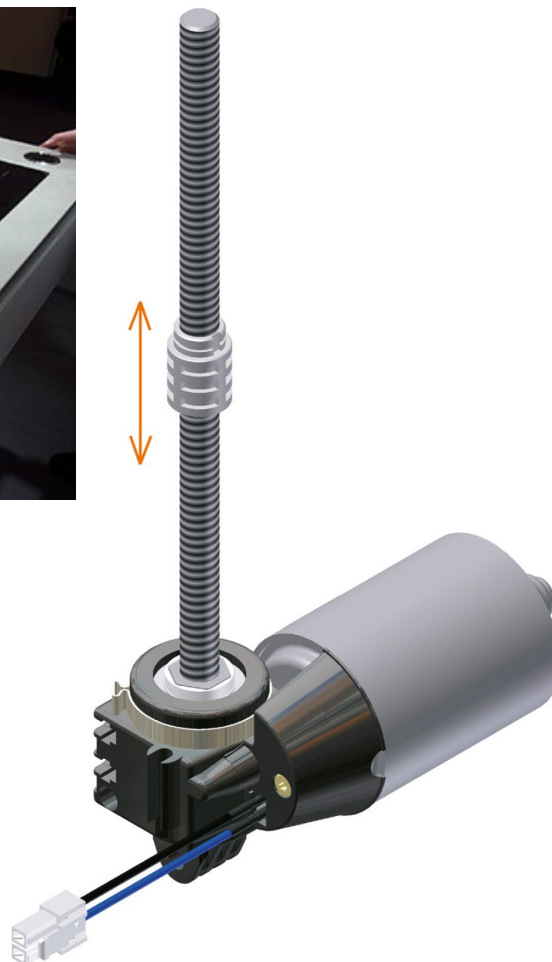

Customized Solution

106743

- DC Motor 18 V
- Speed 95 rpm (24V DC)
- Max. torque 5 Nm

45 mm  
|——|

### Small drive unit paves the way for new extractor hood applications

Design and functionality have an increasingly important role to play in the modern kitchen and new developments in extractor hoods are just one example of this. After use, a motor can lower the extractor hood into the worktop where it waits out of sight until it is next needed.

Ketterer has developed a small and space-saving special drive unit which powerfully, safely and quietly performs this movement. A drive unit, with adjusted spindle and integrated distance measuring system, forms the basis of the clever design. At the touch of a button, the hood is moved out of

the worktop and lowered again in the same way. Various gear reductions and spindle combinations allow the drives to be adapted ideally to the requirements of the situation.

Ketterer has perfectly combined design and functionality in this drive unit. The small and space-saving drives can be integrated into spaces requiring compact, low-noise and powerful drive solutions. See for yourself and contact us!