

Crank lifting system Ket-Twist 500 3052



Description

Ket-Twist 500 is a fast crank lifting system for making custom adjustments to the working height of tables. The system allows a maximum stroke of 500 mm with a minimum clearance of only 625 mm. Each turn of the crank lifts the table 30 mm.

Ket-Twist 500 is ideal for 2-leg table frames with high efficiency guide tubes and handles smoothly and easily under loads of up to 40 kg.

Special features

- Rapid adjustment:
With 16.7 turns for maximum height change
- Customer specific:
Flexible fabrication of connecting tubes
- Quick, easy assembly
- Independence from electrical connections:
Free interior design options

Variant key



Technical data

Stroke:	500 mm
Retracted length E:	625 mm
Recommended table load:	0 – 40 kg
Static self-locking:	≤ 120 kg
Adjustment path per revolution:	30 mm
Spindle pitch:	30 mm
Ratio:	1:1
Gas spring force:	200 N/ Lifting unit

Crank lifting system	Lifting unit (right and left identical)	Connecting tube (customer specific)	Deflection gear with brake unit (customer specific)
Retracted length	625 mm	customer specific	customer specific
Item number	3052.00-0002	3052.40-V01LXXXX	3052.00-V02AXXX

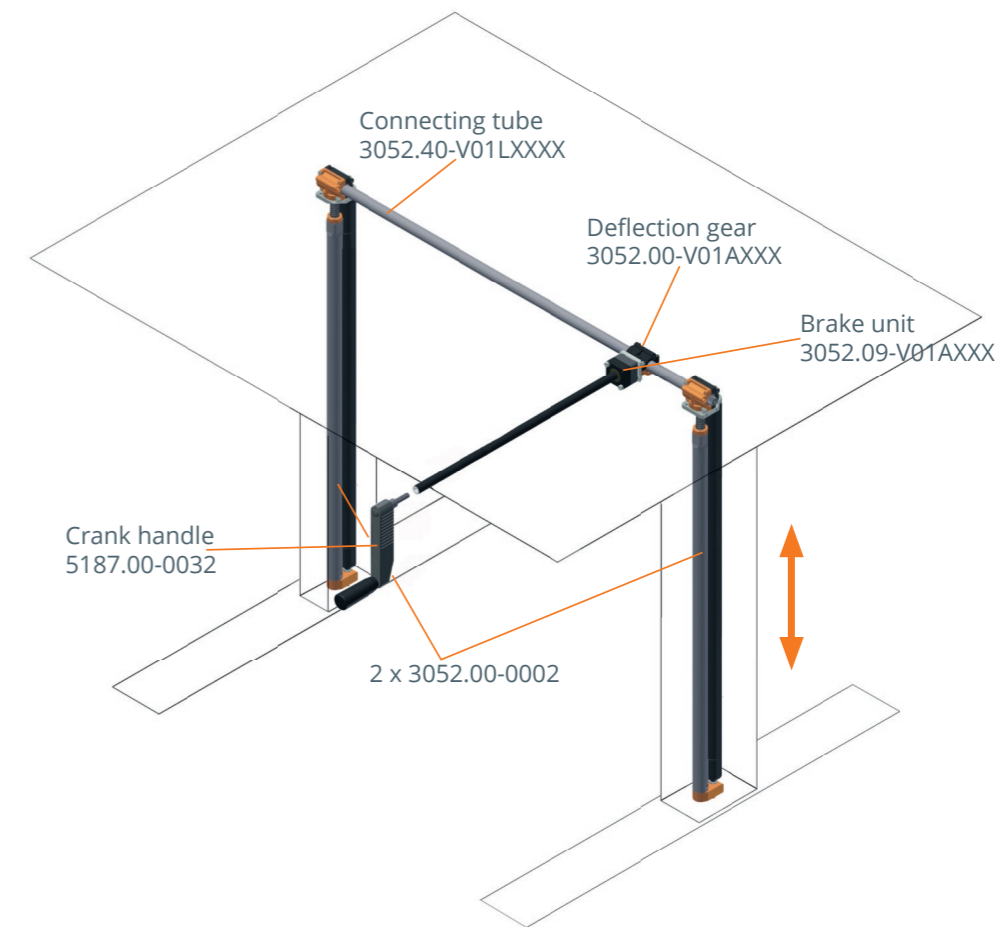

Technical notes

- Optimum user comfort of the overall system can be only achieved by precise matching of the weight of the plate support, the table top and the guide columns as well as the friction loss of the guide. This coordination is necessary, because the characteristics of different table systems are always individual and must be taken into consideration in the system design.
- Lifting system components must be ordered separately.
- Upon request the lifting system can also be custom dimensioned, i.e. other lift and installation lengths are possible.
- Table manufacturer is responsible for integration of the gas spring assembly.
- **Safety instruction:**
Gas springs can develop high acceleration forces. Please handle the assembly and this disassembly with care and diligence.

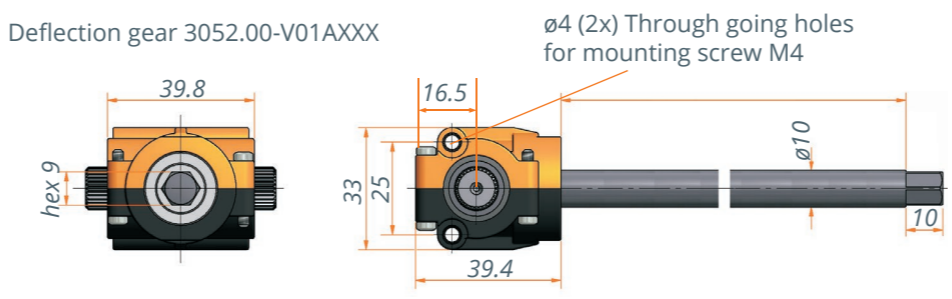
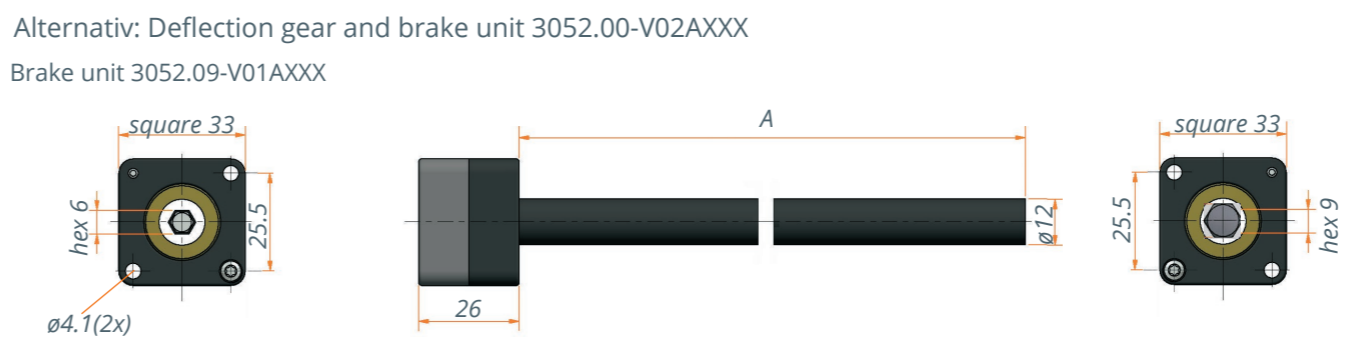
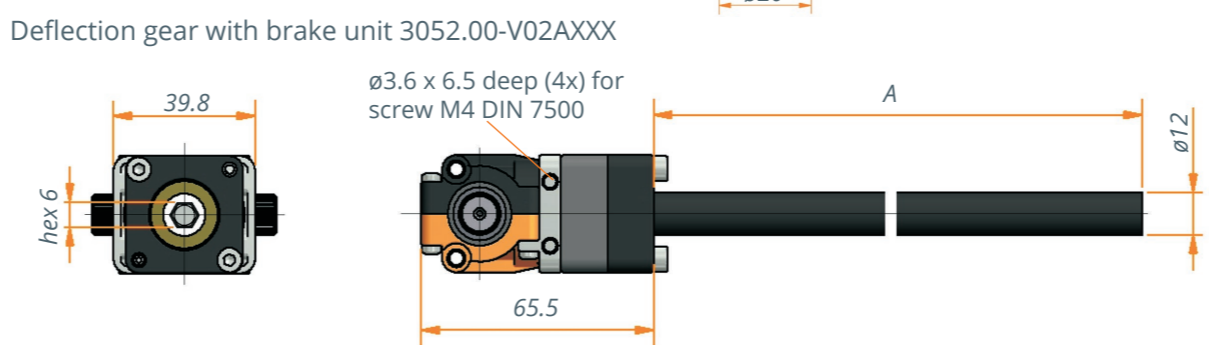
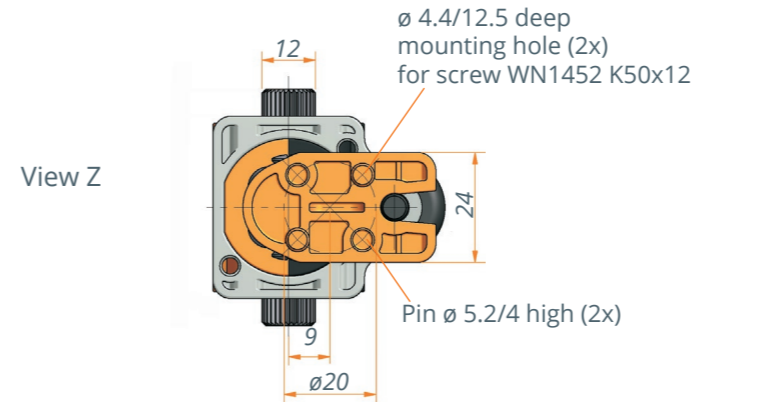
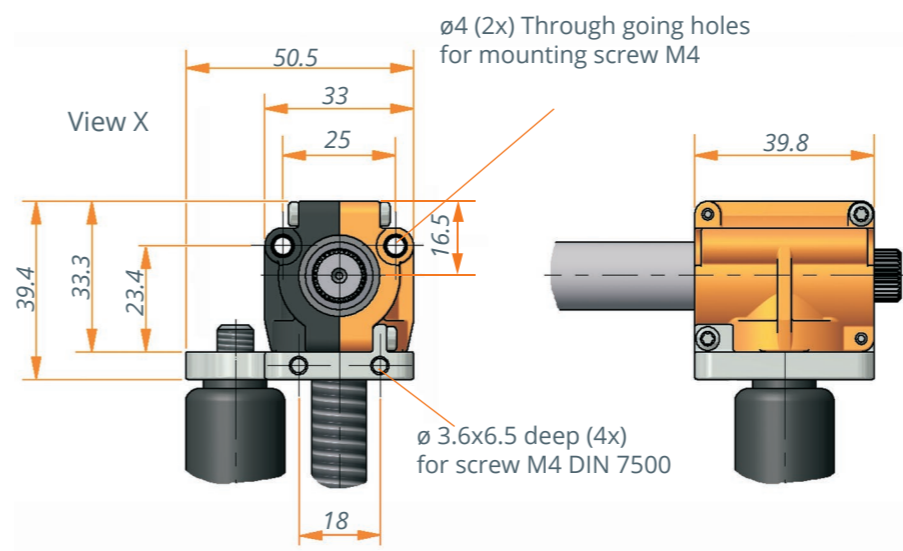

Lifting unit 3052.00-0002

