

Electric spindle drive 4643

Description

Powerful motorized drive unit with push-pull spindle and electromechanical end-switches. Stroke to customer demands. By simplified control function, an additional distance measuring system is not required.

Special features

- Very powerful
- For very high holding torques
- Simple installation
- Two electromechanical end-switches
- Can be adapted easily by fork crown and mounting adapter flange

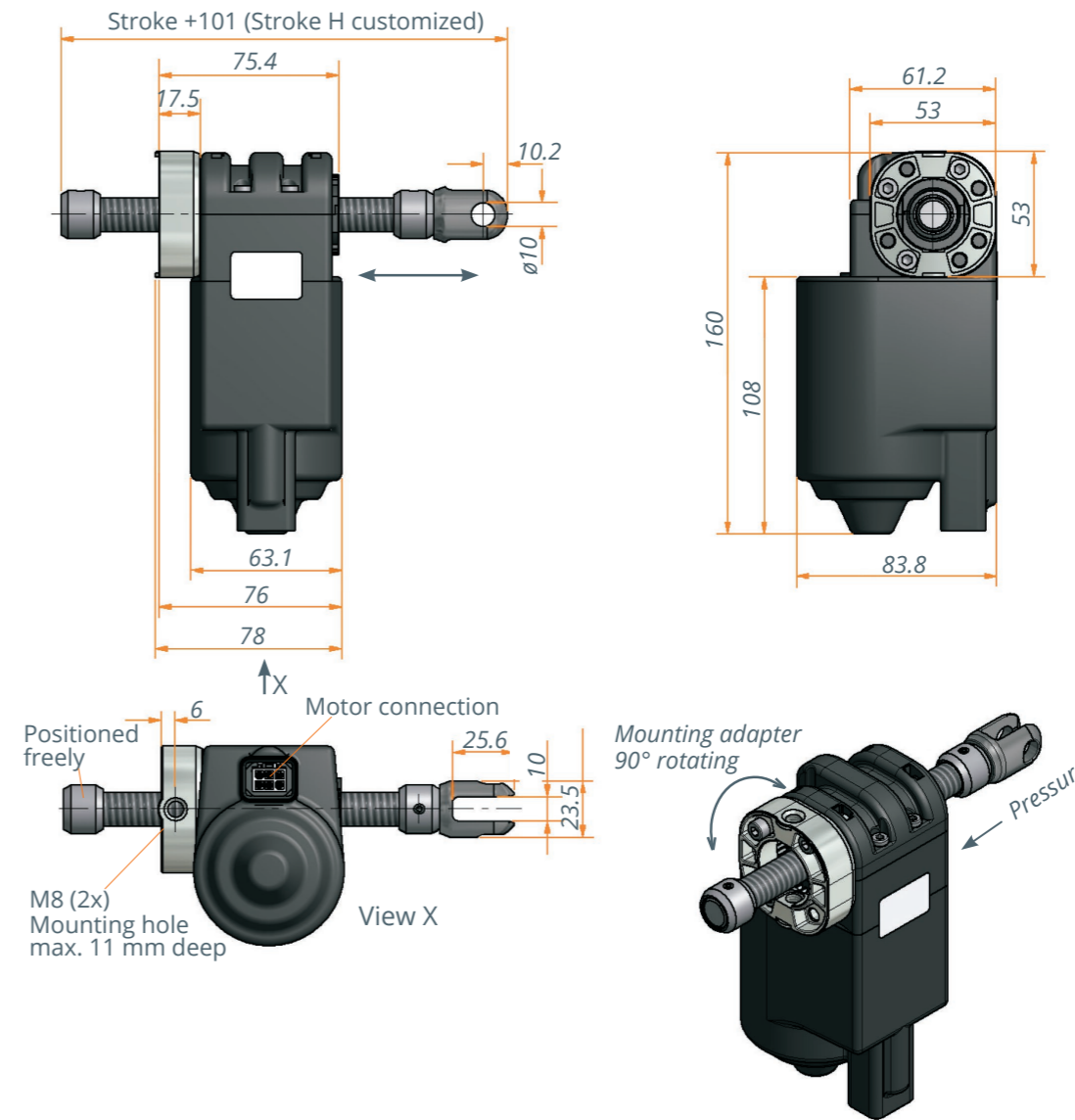

Technical data

Model	4643.00-V01EXXXHXXX
Motor	DC Motor 18 V
Sensor/Powerd supply	Hall/5 V DC/0.3 A
Protection class	IP30
Duty cycle	20% (at 5 min.)
Type of spindle	Tr14x3 RH
Max. pressure force	3000 N
Movement speed	4 mm/s*

* In combination with LogicData control box Compact-3

** Further types of spindles on request

Technical notes

- Depending on the the spindle pitch, the system could back-drive.