

# Ket-Rob - Drive platform for AGV/AGC

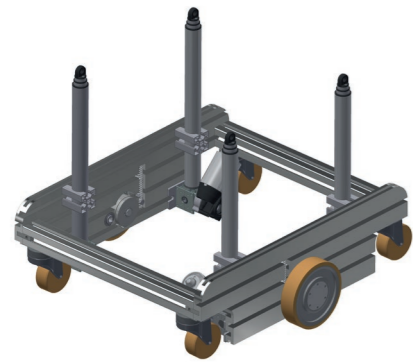

## Description

Tailored to the requirements of autonomous robot technology, Ketterer offers a modular drive platform for **Automated Guided Vehicle** systems or **- Carts (AGV/AGC)**.

All components are designed for simple integration.

## Your benefits

- Complete basic drive module for **Automated Guided Vehicle** systems or **- Carts (AGV/AGC)**
- Dimensioning of the drive platform according to individual requirements
- Gearless BLDC wheel hub drives with a durable Vulkollan or solid rubber wheel
- Noise-reduced direct drive with spring suspension (spring travel 20 mm). Therefore driving on uneven surfaces is not a problem
- Large design scope of the vehicle structure due to very low installation depth of the wheel hub drives
- Very quiet in operation
- Maintenance-free, therefore no maintenance and service needed
- Load platform height adjustment and load platform in accordance with customer-specific requirements optionally possible
- Customer-specific adaptations of the drives or systems are possible



## Technical data

	<i>Ket -Rob</i>
<b>Power supply</b>	24 V- 48 V
<b>Utilize speed</b>	7 km/ h
<b>Acceleration</b>	0.5 m/s <sup>2</sup>
<b>Max. Engine power (per drive unit)</b>	210 W
<b>Load capacity</b>	100 kg
<b>Starting torque (per drive unit)</b>	6 Nm
<b>Braking torque (per brake)</b>	9 Nm
<b>Power supply brake (per drive unit)</b>	24 V/ 18 W
<b>Driving direction</b>	forward and backward
<b>Ground clearance</b>	30 mm
<b>Max. incline</b>	4 %
<b>Protection class</b>	IP 20
<b>Operating temperature</b>	5 to 40 °C (Humidity 10-90 % non-condensing)

Basis: Without height adjustment for transport platform

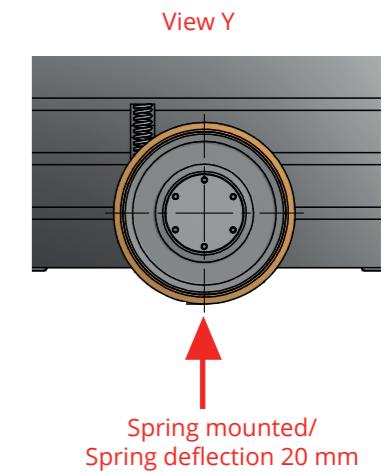
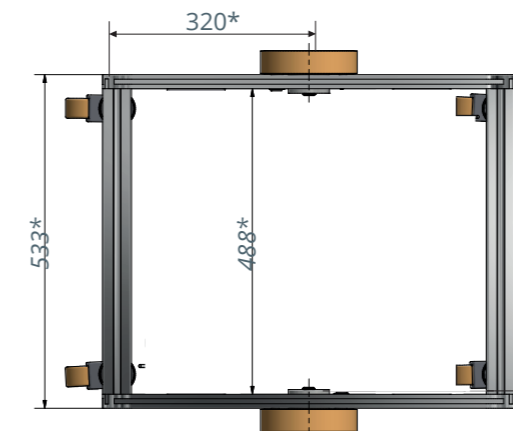
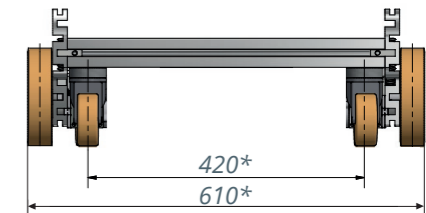
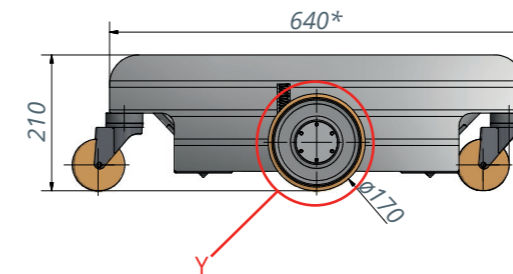

\* Dimensions can be customized

Ket Rob consists in the standard version of:

- 2 x BLDC wheel hub drives with encoder and brake (without regulation/control)
- 4 x load bearing steering wheels
- Frame

Additional options:

- Height adjustment for transport platform
- Transport platform

Additional option: Height adjustment for transport platform

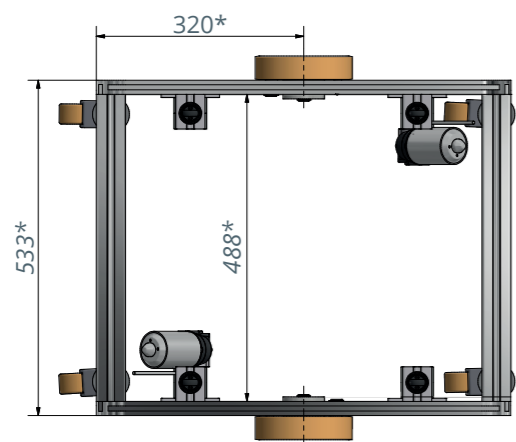
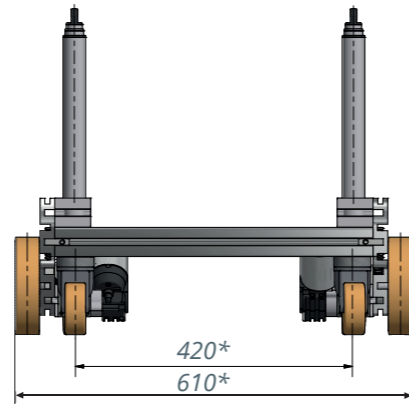
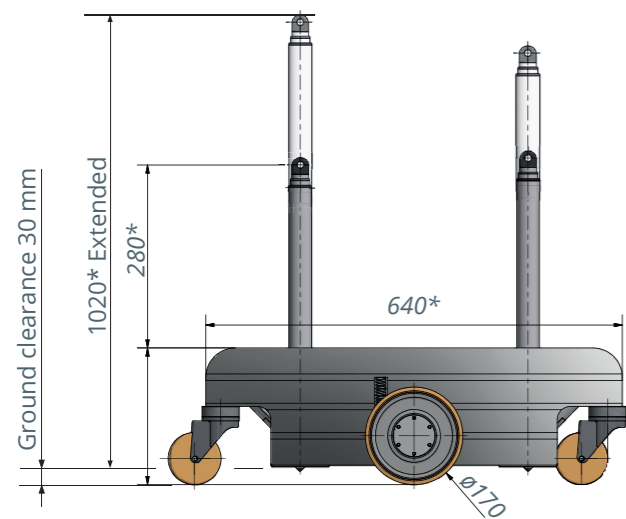

\* Dimensions can be customized

Technical notes

- For the linear height adjustment many Ketterer standard solutions conceivable: e.g. 3120, 4643, 4114, .....
- Information about these products can be found at [www.ketterer-drives.com/products](http://www.ketterer-drives.com/products)
- Customer-specific adaptations are possible



Additional option: Transport platform

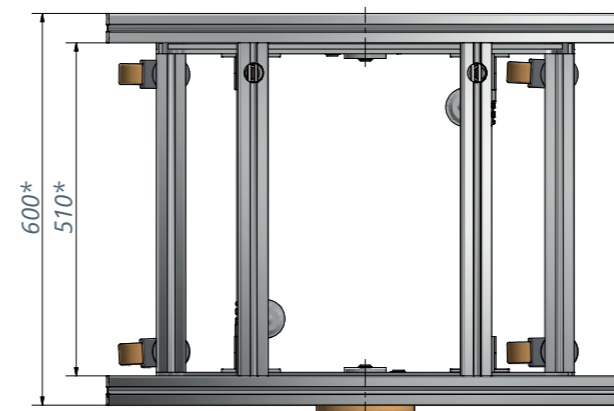
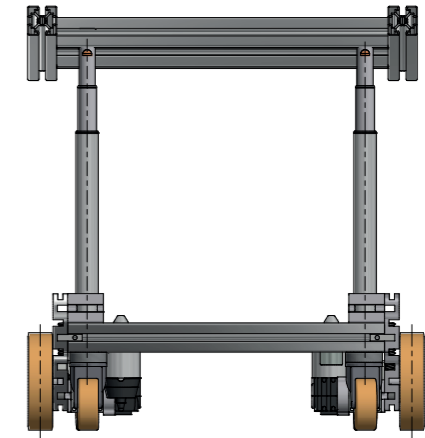
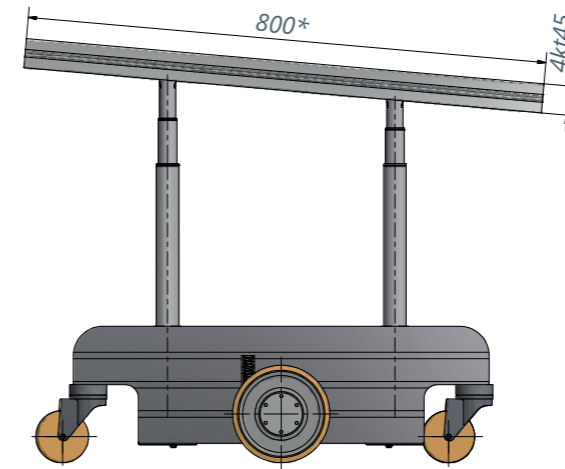

\* Dimensions can be customized

## Orientation aid

In the era of Industry 4.0 and Big Data, it is unimaginable to do without Automated Guided Vehicle Systems (AGVS) and Automated Guided Vehicles (AGV). They have become a component of modern intralogistics solutions.

**Automated Guided Vehicle Systems (AGVS)**  
Automated Guided Vehicle Systems are floor-bound systems that are used in-plant, inside and/or outside of buildings. They essentially consist of one or more automatically controlled vehicles, guided without contact, with their own travel drive and, if necessary, of

- a master controller,
- a device for location determination and position detection
- a device for data transmission and
- infrastructural and peripheral devices

The main task of an AGVS is the automatic transport of materials. In the broader sense, AGVSs also include systems that are used for service tasks such as handling, monitoring, cleaning, mobile information and guidance – including in areas accessible to the general public.

VDI guideline 2510

**Automated Guided Vehicles (AGVs)**  
Automated Guided Vehicles (AGVs) are floor-bound conveyances with their own travel drive, which are automatically controlled and guided without contact. They are used for the transport of materials, i.e. for pulling and/or carrying conveyed goods with active or passive load handling devices. This guideline deals with vehicles with wheel drives. Rail-guided vehicles, air-cushion vehicles and walking machines are excluded.

VDI guideline 2510

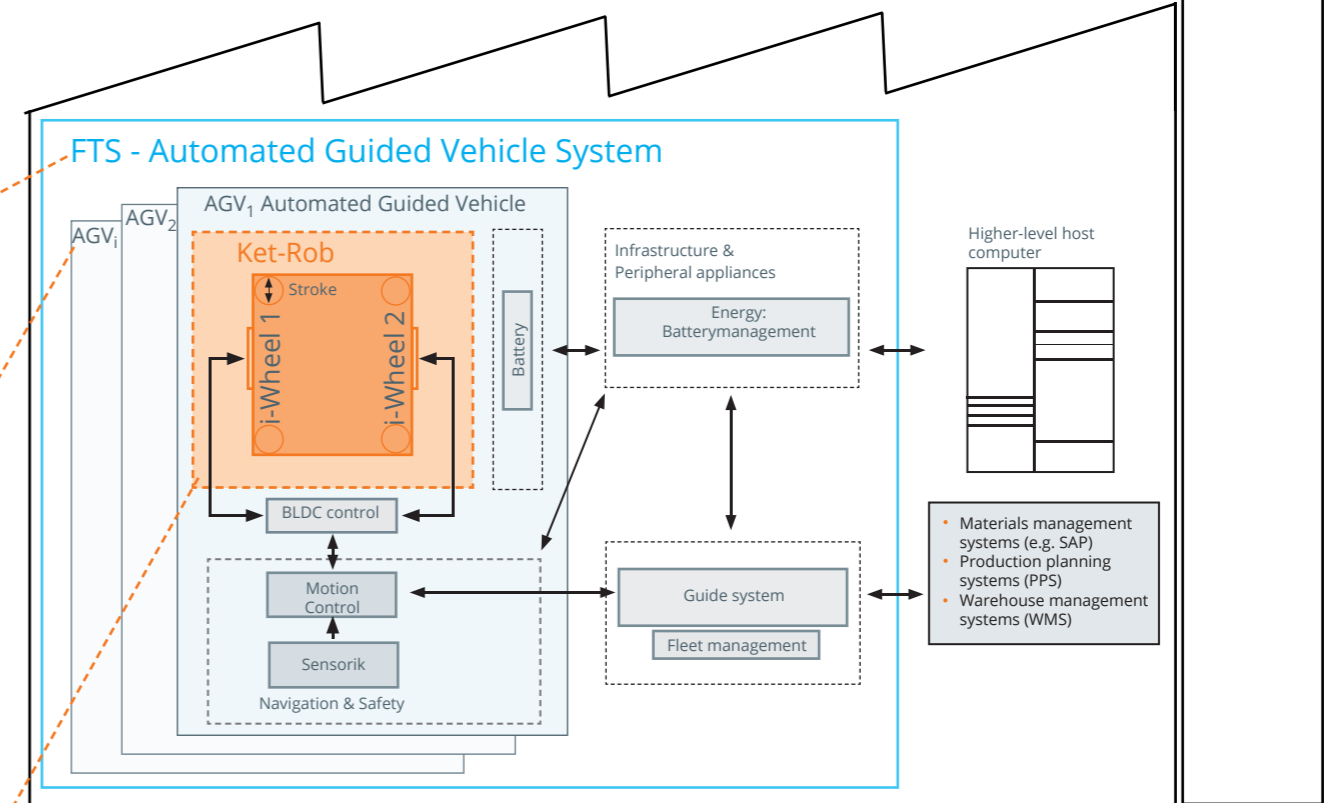

### Ket-Rob – more time for essentials

Ketterer's drive platform „Ket-Rob“ enables the project manager, in the development of an AGV / AGVS, to concentrate on the complex part of the work, i.e. the proprietary application and idea, including the programming and coordination of the necessary control systems. If the controller is to be evaluated, the Ketterer platform enables a prototype for an AGV / AGVS to be created and tested very quickly. The time saved can be used in the development of system variants in order to find the optimum solution for the in-house AGV / AGVS.



More space due to gearless configuration

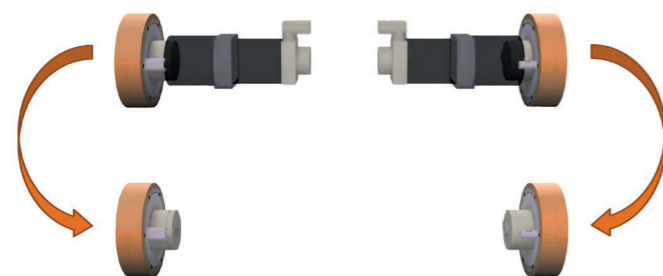

Drives with spring suspension – uneven surfaces are not a problem

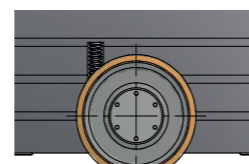

Spring-loaded/  
Spring deflection 20 mm



Variable dimensioning



Frame prepared for the mounting of sensors

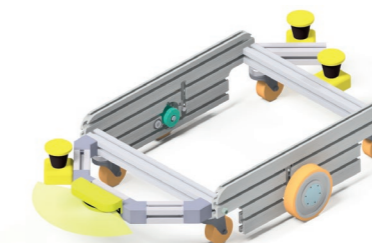

Optionally with lifting and/or tilting unit



# i-Wheel Clever 3213.00-21XX



synapticon  
INTEGRATED MOTION



Wheel hub drive with fully integrated Circulo 9 Motion Controller from Synapticon - a compact, intelligent drive system with minimal integration expenses.

## Direct drive: Advantages in a nutshell

- No gearbox – no wear
- Much longer service life compared to conventional drive technology with a gear stage
- Excellent running properties with barely perceptible noise level
- Safer operation through permanent temperature monitoring
- Ultra-compact with extremely high power density
- Easy replacement of wheel coating on site possible thanks to patented Ketterer solution



## Overall System: Intelligent - Safe - Ultracompact

- Optimum Performance Scaling: Available in all three Ketterer standard performance classes of the i-Wheel family on request
- Highest performance in drive control in the smallest installation space
- Easy to Use: Seamless Integration in a few easy steps
- Plug & Play: Standard plug & standard cable can be used
- High speed EtherCAT interface, low latency, negligible jitter
- Over 10 certified safety functions (SIL2, PL-d) SIL 3, PL-e on request
- High Resolution Absolute Encoder
- User-friendly Synapticon parameterization and tuning software
- Model predictive field-oriented control for high efficiency, maximum bandwidth
- Optional emergency holding brake with energy saving mode
- Available in the near future: Circulo 9 with Safe Motion Module

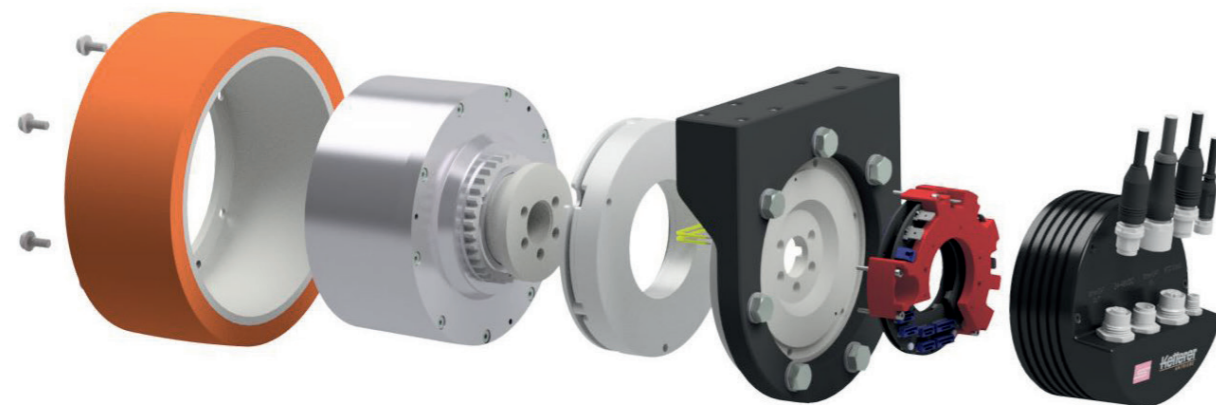

3213.00-21XX i-WheelC-A-170-185	
Rated voltage	48 VDC
Rated current <sup>1)</sup>	4.5 A
Rated torque <sup>1)</sup>	5 Nm
Rated speed <sup>1)</sup>	316 rpm
Max. speed at rated torque <sup>1)</sup>	10 km/h
Shaft power (output) <sup>1)</sup>	165 W
Idle running speed <sup>2)</sup>	450 rpm
No-load current <sup>2)</sup>	0.3 A
Max. efficiency <sup>2)</sup>	82 %
Standstill torque <sup>2)</sup>	19.7 Nm
Starting current at idle speed <sup>2)</sup>	35 A
Max. radial axle load F <sup>3)</sup>	2,500 N
Max. axial axle load F <sup>3)</sup>	1,250 N
Encoder resolution	262,144 cpr
Material of the coating	PU-Rad: 92° ±3° Shore A
Braking torque of the emergency holding brake	16 Nm

- 1) Max. ambient temperature = 40 °C, controller-specific
- 2) At the nominal point (TU = 20°C), controller-specific
- 3) Radial and axial forces apply to the nominal service life L10h = 20,000h according to DIN ISO 281

Circulo 9 Motion Controller by Synapticon	
Communications interface	EtherCAT, FSoE (FailSafe over EtherCAT)
Rated voltage range	24 - 48 V DC
Max. voltage	60 V DC
Continuous phase current RMS	20 A
Max. efficiency	99 %
Hardware Protection	Overcurrent, overvoltage, undervoltage, PW deadtime, overtemperature, PWM shoot through
Standard Safety Functions	STO/SBC
Safe Motion Modul	FSoE, STO, SBC, SS1/2, SOS, SMS, 4xSLS, Safe Process Data (position, velocity)
Certified Safety Functions	STO – SAFE TORQUE OFF SBC – SAFE BRAKE CONTROL SBT – SAFE BRAKE TEST* SS1 – SAFE STOP 1 SS2 – SAFE STOP 2 SLS – SAFELY LIMITED SPEED SLP – SAFELY LIMITED POSITION* SLT – SAFELY LIMITED TORQUE* SAFE VELOCITY PROCESS DATA SAFE POSITION PROCESS DATA SAFE TORQUE PROCESS DATA SAFE DIGITAL GPIO AND ANALOG INPUTS  *The functions must be implemented in the safety controller using secure process data

## i-Wheel Clever 3213 with integrated Circulo 9 Motion Controller by Synapticon

